

MERCHANT BAR REFERENCE GUIDE: DURAGAL® FLATS

| Designation | Weight | Surface Area | Depth d | Thickness t | Length | Quantity |
|-------------|--------|-------------------|---------|-------------|--------|----------|
| | kg/m | m ² /m | mm | mm | m | per pack |
| 50x4.0 | 1.582 | 0.108 | 50 | 4.0 | 6 | 57 |
| 50x5.0 | 1.975 | 0.110 | 50 | 5.0 | 6 | 45 |
| 65x5.0 | 2.567 | 0.140 | 65 | 5.0 | 6 | 36 |
| 75x4.0 | 2.373 | 0.158 | 75 | 4.0 | 6 | 38 |
| 75x5.0 | 2.962 | 0.160 | 75 | 5.0 | 6 | 32 |
| 100x4.0 | 3.165 | 0.208 | 100 | 4.0 | 6 | 28 |
| 100x5.0 | 3.950 | 0.210 | 100 | 5.0 | 6 | 28 |
| 100x6.0 | 4.829 | 0.212 | 100 | 6.0 | 6 | 26 |
| 130x5.0 | 5.134 | 0.270 | 130 | 5.0 | 6 | 28 |
| 150x5.0 | 5.924 | 0.310 | 150 | 5.0 | 6 | 28 |
| 150x6.0 | 7.243 | 0.312 | 150 | 6.0 | 6 | 24 |
| 200x6.0 | 9.657 | 0.512 | 250 | 6.0 | 6 | 28 |
| 250x5.0 | 9.874 | 0.510 | 250 | 5.0 | 6 | 23 |

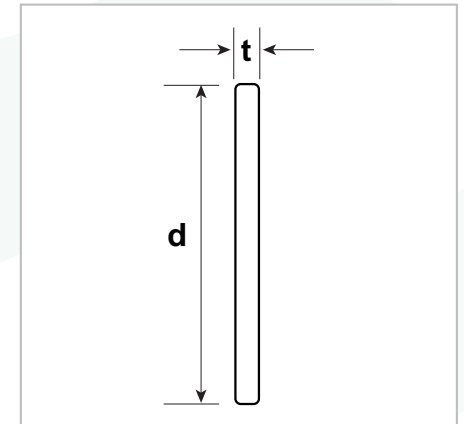

- A minimum of 100g/m² coating of zinc is applied by in-line galvanising to a mechanically (shot blasted) and chemically cleaned bright metal (AS 1627.4 Class 3.0) surface. A clear polymer barrier coating protects the galvanising prior to fabrication.
- DuraGal® is readily welded. Its thin evenly applied inline galvanised coating ensures minimal welding fumes. No need to preheat, change consumables or welding settings.
- Some items may require a 3 pack minimum order quantity.

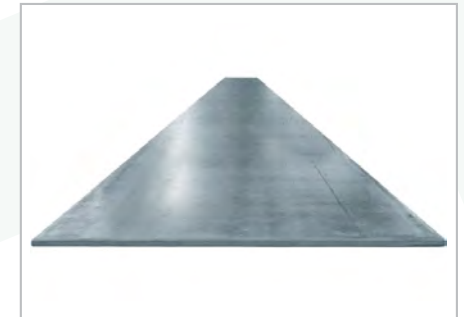